



## 卧式螺带混合机 RIBBON MIXER



粉体混合  
Powder mixing

颗粒混合  
Granulu mixing

冷却/加热  
Cooling/heating



TEL: 86-021-69176576 69176577

上海市嘉定区南翔高科技园区 ( 胜辛南路399号 )

Number .399, South Shengxin Road, Nanxiang High-teech Garden,  
Jiading District, Shanghai City, China

**升立机械**  
粉体技术实业专家

CN: WWW.1985MIXER.COM

EN: WWW.1985BLENDER.COM

SL@1985MIXER.COM

# LHY 卧式螺带混合机

## LHY RIBBON MIXER

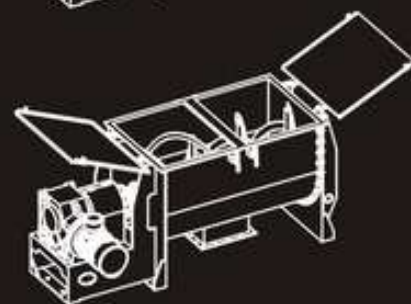
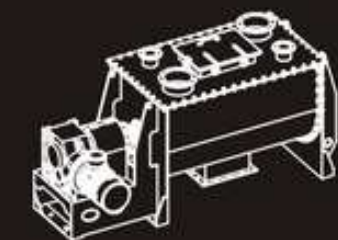
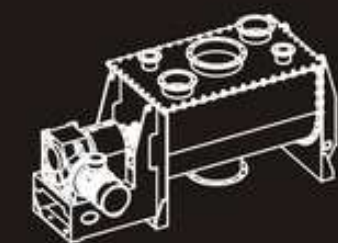

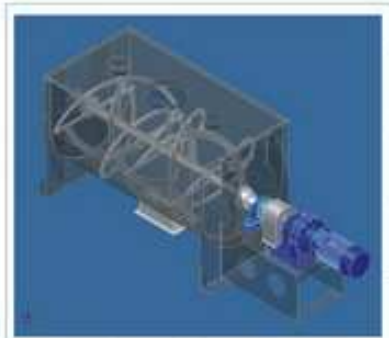

### Driven unit

可靠的驱动配置



### 灵活的选材方案 Material selection



### 高效的搅拌装置 Blending device



### 优异的放料装置 Discharging unit



### 精细的加液控制 Liquid-adding unit



### 严密的动轴密封 Dynamic sealing



### 强大的辅助组件 Auxiliary component



### 卓越的控制系统 Control system



最佳混合均匀度  
最短的混合时间  
超低的故障率  
高产的混合效率  
往复性批次混合

Best mixing homogeneity  
Shortest mixing time  
Low failure rate  
High mixing efficiency  
Repeated batch mixing

使用范围：

LHY 卧式螺旋带混合机在化工、医药、食品、建材等领域广泛使用，可用于粉体与粉体的混合、粉体添加少量液体混合、粉体与颗粒的混合等工艺。

Scope of application:

LHY horizontal ribbon mixer is widely used in Chemical, pharmaceutical, food and construction line. It can be used to mix different powders, powder with a small amount of liquid, and powder with granule.

工作原理：

外螺旋带盘绕形式配合旋转方向把物料从两端向中间推动，而内螺旋带把物料从中间向两端推动，形成对流混合。混合机卧式筒体底部中央开设出料口，外层螺旋带的螺旋结构配合主轴旋转方向驱赶筒壁内侧物料至中央出料口出料，确保筒体内物料出料无死角。

Working principle:

The outer helix combined with rotation direction drive material from two ends of vessel to center; while the inner helix drive material from center to both ends. The vortex structure of outer helix combined with rotation of main shaft drive material to discharge outlet guaranteeing no dead corner.

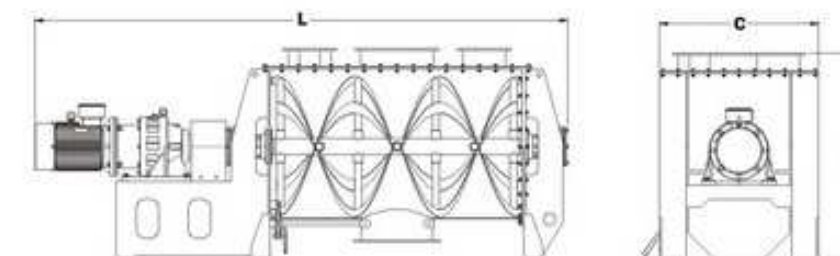

规格型号 specification	LHY-0.3	LHY-0.5	LHY-1	LHY-2	LHY-3	LHY-4	LHY-5	LHY-6	LHY-8	LHY-10	LHY-15	LHY-20	LHY-30
有效容积 (M³) working capacity	0.18	0.3	0.6	1.2	1.8	2.4	3	3.6	4.8	6	9	12	18
批次最大产量KG working capacity	200	300	600	1200	1800	2500	3000	3600	4800	6000	9000	12000	15000
转速 (r/min) speed(rpm)	62	62	49	33	33	27	27	27	22	22	14	14	12
驱动功率KW power(KW)	5.5	7.5	11	15	18.5	22	30	37	45	55	75	90	110
设备重量(kg) weight(kg)	600	900	1200	2000	2500	3500	4000	4500	5000	6000	7500	10500	13000
L	2280	2670	3140	3860	4460	4950	5280	5530	5100	5610	5820	6300	7000
C	680	780	980	1200	1300	1400	1550	1560	1720	1750	2000	2350	2600
H	880	1240	1400	1650	1700	2000	2100	2200	2500	2650	2900	3160	3350

以上为标准型设备参数，非标准型设备参数参照设备图纸。

The above is the parameter for standard equipment, Non-standard equipment please refer to the drawing.

小型简易生产流程示意  
以及配套设备

Simple production line  
& related machine

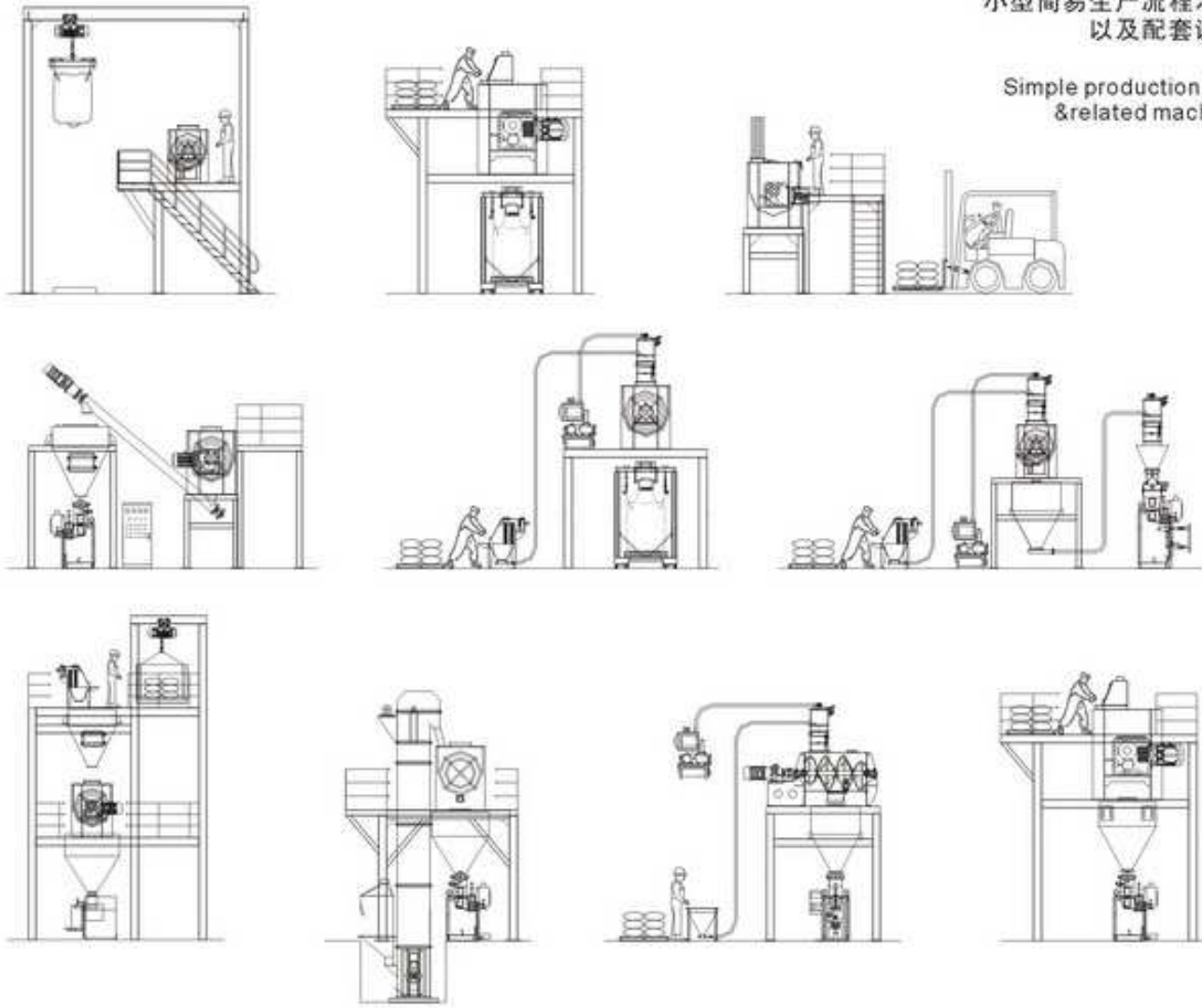

**PC** 真空上料机  
Vacuum conveyer



**GLS** 螺旋输送机  
Screw conveyer



变速喂料器  
Variable speed feeder



**DC** 粉末除尘器  
Dust collector



除尘投料站  
Dust proof feeder



**HCB** 自动包装机  
Automatic packer



**DCB** 大袋包装机  
Bulk-bag packer



大袋卸料站  
Bulk -bag dischargers